

# FANUC Robot ARC Mate 100*i*C

# FANUC Robot ARC Mate 120*i*C



## FEATURES

FANUC Robot ARC Mate 100*i*C / 120*i*C is torch cable integrated arc welding robot.

- ARC Mate 100*i*C Standard type, short arm type (12S), long arm type (7L) and ARC Mate 120*i*C Standard type, long arm type (12L) are available for various application adaptation.
- High rigidity arm and advanced servo technology enable to increase acceleration performance. This decreases cycle time and realizes high productivity.
- The unique drive mechanism in wrist axis realizes the slim arm in torch cable integrated robot.
- Smooth hand cable routing and easy maintenance by cantilevered fore arm provides excellent cable management with stable wire feeding.
- Thanks to stable hand cable management, off-line teaching function by ROBOGUIDE (Option) reduces teaching cost.
- Latest intelligent functions with *i*RVision (integrated vision) and Coordinated motion with Positioner are available.

## Application system



Automobile part arc welding with Servo Torch



Architectural part arc welding with *i*RVision

# FANUC Robot ARC Mate 100iC/120iC

## Operating space

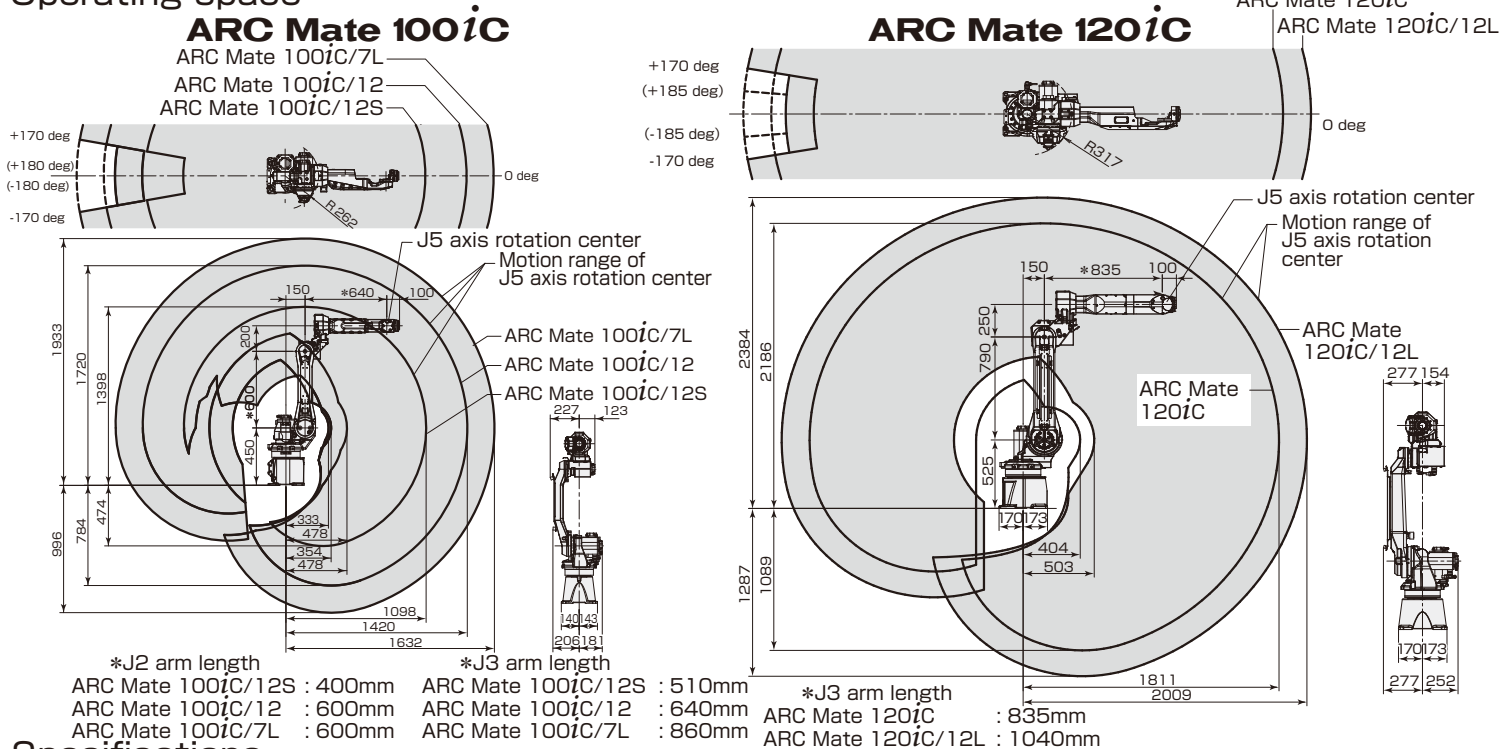

## Specifications

Item	Specifications					
	ARC Mate 100iC/12S	ARC Mate 100iC/12	ARC Mate 100iC/7L	ARC Mate 120iC	ARC Mate 120iC/12L	
Type	6 axes (J1, J2, J3, J4, J5, J6)					
Reach	1098mm	1420mm	1632mm	1811mm	2009mm	
Installation	Floor, Upside-down, Angle mount					
Motion range (Maximum speed) (Note 1, 2)	J1 axis rotation	340°/360° (option) (260°/s) 5.93 rad/6.28 rad (option) (4.54 rad/s)	340°/360° (option) (230°/s) 5.93 rad/6.28 rad (option) (4.01 rad/s)	340°/370° (option) (195°/s) 5.93 rad/6.45 rad (option) (3.40 rad/s)	340°/370° (option) (200°/s) 5.93 rad/6.45 rad (option) (3.49 rad/s)	
	J2 axis rotation	250° (280°/s) 4.36 rad (4.89 rad/s)	250° (225°/s) 4.36 rad (3.93 rad/s)	260° (175°/s) 4.54 rad (3.05 rad/s)		
	J3 axis rotation	340° (315°/s) 5.93 rad (5.50 rad/s)	445° (230°/s) 7.76 rad (4.01 rad/s)	447° (230°/s) 7.80 rad (4.01 rad/s)	458° (180°/s) 8.00 rad (3.14 rad/s)	460° (190°/s) 8.04 rad (3.32 rad/s)
	J4 axis wrist rotation		380° (430°/s) 6.63 rad (7.50 rad/s)		400° (360°/s) 6.98 rad (6.28 rad/s)	400° (430°/s) 6.98 rad (7.50 rad/s)
	J5 axis wrist swing		380° (430°/s) 6.63 rad (7.50 rad/s)		360° (360°/s) 6.28 rad (6.28 rad/s)	360° (430°/s) 6.28 rad (7.50 rad/s)
	J6 axis wrist rotation		720° (630°/s) 12.57 rad (11.0 rad/s)		900° (550°/s) 15.71 rad (9.60 rad/s)	900° (630°/s) 15.71 rad (11.0 rad/s)
Maximum load capacity at wrist	12 kg		7 kg	20 kg	12 kg	
Allowable load moment at wrist	J4 axis	22.0 N·m	15.7 N·m	44.0 N·m	22.0 N·m	
	J5 axis	22.0 N·m	10.1 N·m	44.0 N·m	22.0 N·m	
	J6 axis	9.8 N·m	5.9 N·m	22.0 N·m	9.8 N·m	
Allowable load inertia at wrist	J4 axis	0.65 kg·m <sup>2</sup>	0.63 kg·m <sup>2</sup>	1.04 kg·m <sup>2</sup>	0.65 kg·m <sup>2</sup>	
	J5 axis	0.65 kg·m <sup>2</sup>	0.38 kg·m <sup>2</sup>	1.04 kg·m <sup>2</sup>	0.65 kg·m <sup>2</sup>	
	J6 axis	0.17 kg·m <sup>2</sup>	0.061 kg·m <sup>2</sup>	0.28 kg·m <sup>2</sup>	0.17 kg·m <sup>2</sup>	
Repeatability	± 0.05 mm		± 0.08 mm			
Mass (Note 3)	130 kg		135 kg	250 kg		
Installation environment	Ambient temperature : 0 ~ 45°C Ambient humidity : Normal 75%RH or less (No dew not frost allowed), Short term 95%RH or less (within one month) Vibration acceleration : 4.9m/s <sup>2</sup> (0.5G) or less					

Note 1) In case of angle mounting, J1 and J2 axis motion range are restricted.

Note 2) In case of short distance motion, the axis speed may not reach the maximum value stated.

Note 3) Without controller

# FANUC CORPORATION

•Headquarters Oshino-mura, Yamanashi 401-0597, Japan  
 Phone: 81-555-84-5555 Fax: 81-555-84-5512 <http://www.fanuc.co.jp>

•Overseas Affiliated Companies  
 FANUC America Corporation  
 FANUC Europe Corporation, S.A.  
 SHANGHAI-FANUC Robotics CO., LTD.  
 KOREA FANUC CORPORATION  
 TAIWAN FANUC FA Corporation  
 FANUC INDIA PRIVATE LIMITED  
 FANUC SINGAPORE PTE. LTD.  
 FANUC THAI LIMITED  
 FANUC MECHATRONICS (MALAYSIA) SDN. BHD.  
 PT. FANUC INDONESIA  
 FANUC OCEANIA PTY. LIMITED  
 FANUC SOUTH AFRICA (PROPRIETARY) LIMITED

3900 West Hamlin Road, Rochester Hills, MI 48309-3253, U.S.A.  
 Zone Industrielle, L-6468 Echternach, Grand-Duché de Luxembourg  
 No. 1500 Fulian Road, Baoshan Area, Shanghai, China  
 101, Wanam-ro(st), Seongsan-gu, Changwon-si, Gyeongsangnam-do, 641-290 Republic of Korea  
 No.10, 16th Road, Taichung Industrial Park, Taichung, Taiwan  
 41-A, Electronics City, Bangalore, 560 100, India  
 No.1 Teban Gardens Crescent, Singapore 608919, Singapore  
 1301 Pattanakarn Road, Kwaeng Suanluang, Khet Suanluang, Bangkok 10250 Thailand  
 No.32, Jalan Pengacara U1/48, Temasya Industrial Park, Section U1, Glenmarie,  
 40150 Shah Alam, Selangor Darul Ehsan, Malaysia  
 J.L. Boulevard Bukit Gading Raya Blok R, Jakarta 14240 Indonesia  
 10 Healey Circuit, Huntingwood, NSW 2148, Australia  
 17 Loper Ave, Aeroport Industrial Ests. Spartan Ext.2 P.O.Box 219, Isando 1600, Republic of South Africa

Phone: 1-248-377-7000 Fax: 1-248-377-7477  
 Phone: 352-727777-1 Fax: 352-727777-403  
 Phone: 86-21-5032-7700 Fax: 86-21-5032-7711  
 Phone: 82-55-278-1200 Fax: 82-55-284-9826  
 Phone: 886-4-2359-0522 Fax: 886-4-2359-0771  
 Phone: 91-80-2852-0057 Fax: 91-80-2852-0051  
 Phone: 65-6567-8566 Fax: 65-6566-5937  
 Phone: 66-2-714-6111 Fax: 66-2-714-6120  
 Phone: 60-3-7628-0110 Fax: 60-3-7628-0220  
 Phone: 62-21-4584-7285 Fax: 62-21-4584-7288  
 Phone: 61-2-8822-4600 Fax: 61-2-8822-4666  
 Phone: 27-11-392-3610 Fax: 27-11-392-3615

- All specifications are subject to change without notice.
- No part of this catalog may be reproduced in any form.
- The products in this catalog are controlled based on Japan's "Foreign Exchange and Foreign Trade Law". The export from Japan may be subject to an export license by the government of Japan. Further, re-export to another country may be subject to the license of the government of the country from where the product is re-exported. Furthermore, the product may also be controlled by re-export regulations of the United States government. Should you wish to export or re-export these products, please contact FANUC for advice.