

FANUC Robot ARC Mate 100iC



FEATURES

FANUC Robot ARC Mate 100iC is torch cable integrated intelligent arc welding robot.

- The robot covers the motion range from 1.4m to 2.0m reach for various application adaptation. Spare parts such as motor, reducer and controller are communized among all ARC Mate 100iC model.
- The robot can position the tip of wire without vibration, even after high speed air cut motion. High speed and high accuracy motion can improve the productivity of the system.
- The unique gear drive mechanism in wrist axes realizes the slim arm in torch cable integrated robot.
- Welding cable utilities are integrated in the arm. It makes system setup easy.
- Thanks to torch cable management, off-line teaching function by ROBOGUIDE (Option) reduces teaching cost.
- Latest intelligent functions with *i*RVision (integrated vision) and coordinated motion with positioner are available.

Application system



Automobile part arc welding with Servo Torch

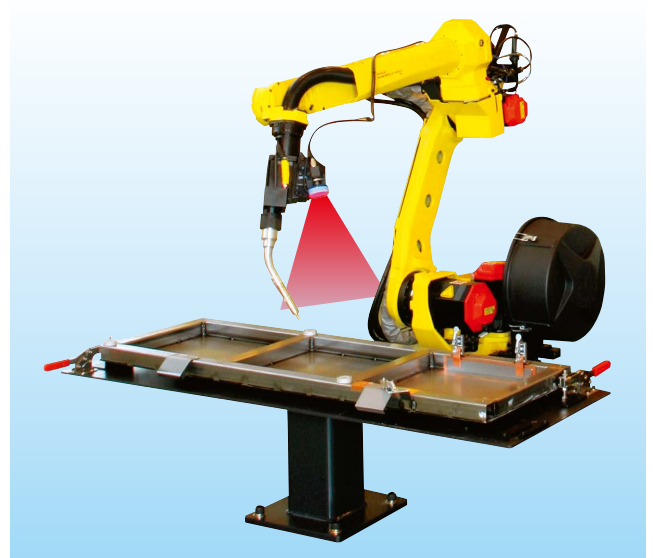

Architectural part arc welding with *i*RVision

Operating space

ARC Mate 100iC

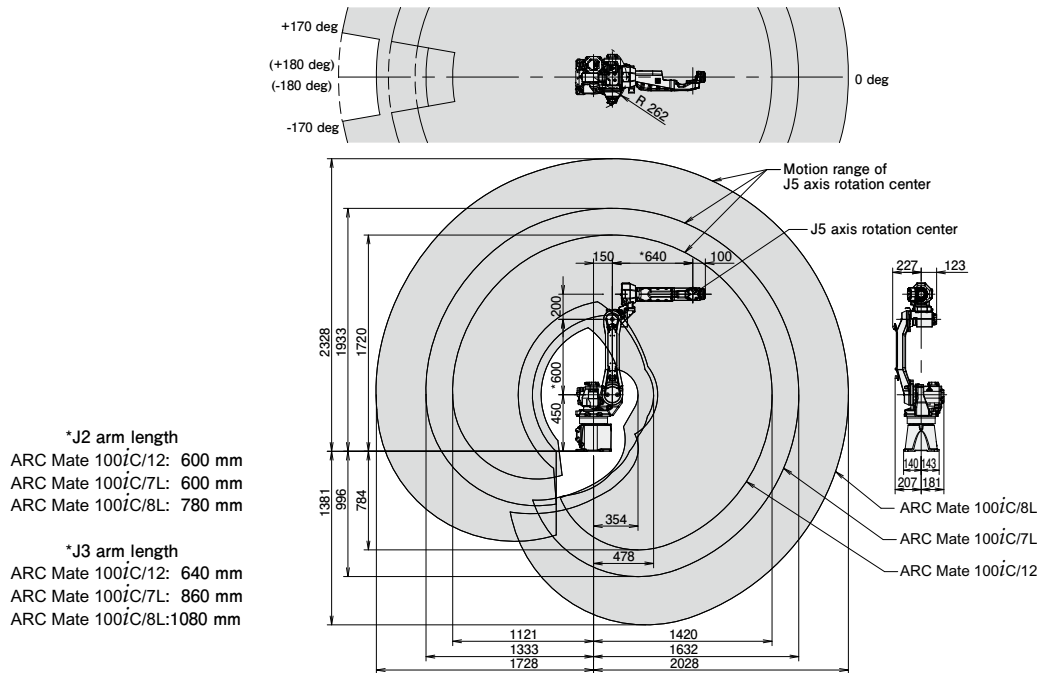

Specifications

Model		ARC Mate 100iC/12	ARC Mate 100iC/7L	ARC Mate 100iC/8L
Controlled axes		6 axes (J1, J2, J3, J4, J5, J6)		
Reach		1420 mm	1632 mm	2028 mm
Installation		Floor, Upside-down, Angle mount		
Motion range (Maximum speed) (Note 1, 2)	J1 axis rotation	340° / 360° (Option) (230°/s) 5.93 rad / 6.28 rad (Option) (4.01 rad/s)		340° / 370° (Option) (200°/s) 5.93 rad / 6.45 rad (Option) (3.49 rad/s)
	J2 axis rotation	250° (225°/s) 4.36 rad (3.93 rad/s)		255° (200°/s) 4.45 rad (3.49 rad/s)
	J3 axis rotation	445° (230°/s) 7.76 rad (4.01 rad/s)	447° (230°/s) 7.80 rad (4.01 rad/s)	462° (210°/s) 8.06 rad (3.67 rad/s)
	J4 axis wrist rotation	380° (430°/s) 6.63 rad (7.50 rad/s)		400° (430°/s) 6.98 rad (7.50 rad/s)
	J5 axis wrist swing	380° (430°/s) 6.63 rad (7.50 rad/s)		360° (430°/s) 6.28 rad (7.50 rad/s)
	J6 axis wrist rotation	720° (630°/s) 12.57 rad (11.0 rad/s)		900° (630°/s) 15.71 rad (11.00 rad/s)
Max. load capacity at wrist		12 kg	7 kg	8 kg
Allowable load moment at wrist	J4 axis	22.0 N·m	15.7 N·m	16.1 N·m
	J5 axis	22.0 N·m	10.1 N·m	16.1 N·m
	J6 axis	9.8 N·m	5.9 N·m	5.9 N·m
Allowable load inertia at wrist	J4 axis	0.65 kg·m ²	0.63 kg·m ²	0.63 kg·m ²
	J5 axis	0.65 kg·m ²	0.38 kg·m ²	0.63 kg·m ²
	J6 axis	0.17 kg·m ²	0.061 kg·m ²	0.061 kg·m ²
Repeatability		± 0.08 mm		
Mass (Note 3)		130 kg	135 kg	150 kg
Installation environment		Ambient temperature : 0 to 45°C Ambient humidity : Normally 75%RH or less (No dew nor frost allowed), Short term 95%RH or less (within one month) Vibration acceleration : 4.9m/s ² (0.5G) or less		

Note 1) In case of angle mounting, J1 and J2 axis motion range are restricted.

Note 2) In case of short distance motion, the axis speed may not reach the maximum value stated.

Note 3) Without controller

FANUC CORPORATION

Headquarters Oshino-mura, Yamanashi 401-0597, Japan

Phone: 81-555-84-5555 Fax: 81-555-84-5512 <http://www.fanuc.co.jp>

●Overseas Affiliated Companies
 FANUC America Corporation
 FANUC Europe Corporation, S.A.
 SHANGHAI-FANUC Robotics CO., LTD.
 KOREA FANUC CORPORATION
 TAIWAN FANUC CORPORATION
 FANUC INDIA PRIVATE LIMITED
 FANUC SINGAPORE PTE. LTD.
 FANUC THAI LIMITED
 FANUC MECHATRONICS (MALAYSIA) SDN. BHD.
 PT. FANUC INDONESIA
 FANUC OCEANIA PTY. LIMITED
 FANUC SOUTH AFRICA (PROPRIETARY) LIMITED

3900 West Hamlin Road, Rochester Hills, MI 48309-3253, U.S.A.
 Zone Industrielle, L-6468 Echternach, Grand-Duché de Luxembourg
 No. 1500 Fulian Road, Baoshan Area, Shanghai, China
 101, Wanam-ro(st), Seongsan-gu, Changwon-si, Gyeongsangnam-do, 642-290 Republic of Korea
 No.10, 16th Road, Taichung Industrial Park, Taichung, Taiwan
 41-A, Electronics City, Bangalore, 560 100, India
 No.1 Teban Gardens Crescent, Singapore 608919, Singapore
 1301 Pattanakarn Road, Kwaeng Suanluang, Khet Suanluang, Bangkok 10250 Thailand
 No.32, Jalan Pengacara U1/48, Temasya Industrial Park, Section U1, Glenmarie,
 40150 Shah Alam, Selangor Darul Ehsan, Malaysia
 J.L. Boulevard Bukit Gading Raya Blok R, Jakarta 14240 Indonesia
 10 Healey Circuit, Huntingwood, NSW 2148, Australia
 17 Loper Ave, Aeroport Industrial Ests. Spartan Ext.2 P.O.Box 219, Isando 1600, Republic of South Africa

Phone: 1-248-377-7000 Fax: 1-855-774-7051
 Phone: 352-727777-1 Fax: 352-727777-403
 Phone: 86-21-5032-7700 Fax: 86-21-5032-7711
 Phone: 82-55-278-1200 Fax: 82-55-284-9826
 Phone: 886-4-2359-0522 Fax: 886-4-2359-0771
 Phone: 91-80-2852-0057 Fax: 91-80-2852-0051
 Phone: 65-6567-8566 Fax: 65-6566-5937
 Phone: 66-2-714-6111 Fax: 66-2-714-6120
 Phone: 60-3-7628-0110 Fax: 60-3-7628-0220
 Phone: 62-21-4584-7285 Fax: 62-21-4584-7288
 Phone: 61-2-8822-4600 Fax: 61-2-8822-4666
 Phone: 27-11-392-3610 Fax: 27-11-392-3615

●All specifications are subject to change without notice.
 ●No part of this catalog may be reproduced in any form.
 ●The products in this catalog are controlled based on Japan's "Foreign Exchange and Foreign Trade Law". The export from Japan may be subject to an export license by the government of Japan. Further, re-export to another country may be subject to the license of the government of the country from where the product is re-exported. Furthermore, the product may also be controlled by re-export regulations of the United States government. Should you wish to export or re-export these products, please contact FANUC for advice.

© FANUC CORPORATION, 2015
 ARCMate100iC(E)-01, 2015.4, Printed in Japan