

Small Payload Handling Intelligent Robot

FANUC Robot M-10iA



Features

FANUC Robot M-10iA is a small payload handling robot whose payload is 7 to 12kg.

- The robot covers the motion range from 1.4m to 2.0m reach for various application adaptation. Spare parts such as motor, reducer and controller are communized among all M-10iA model.
- The robot can position tools without vibration, even after high speed motion. High speed and high accuracy motion can improve the productivity of the system.
- The unique gear drive mechanism in wrist axes realizes the slim arm in torch cable integrated robot.
- Hand cable utilities are integrated in the arm. And the tool controller is on J3 casing. It makes system setup easy.
- Thanks to hand cable management, off-line teaching function by ROBOGUIDE (Option) reduces teaching cost.
- Latest intelligent functions with iRvision (integrated vision) and force sensor are available.

Application system



Small parts bin picking

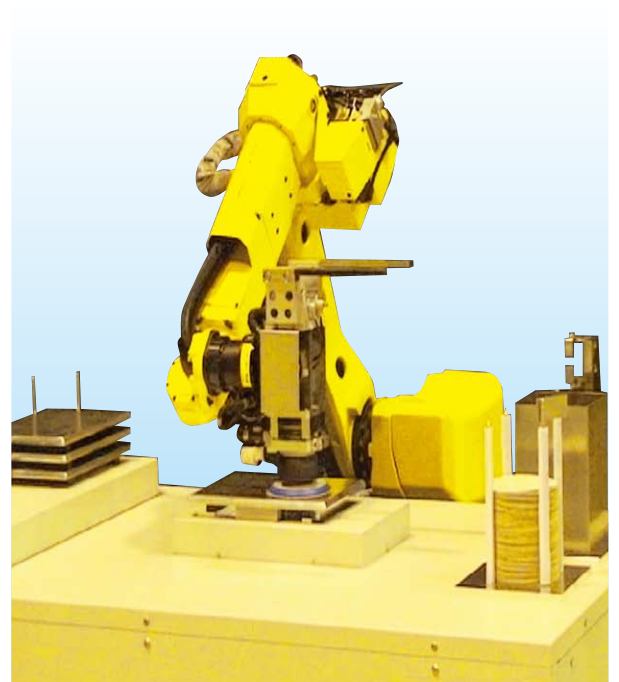

Case parts polishing

Operating space

M-10iA

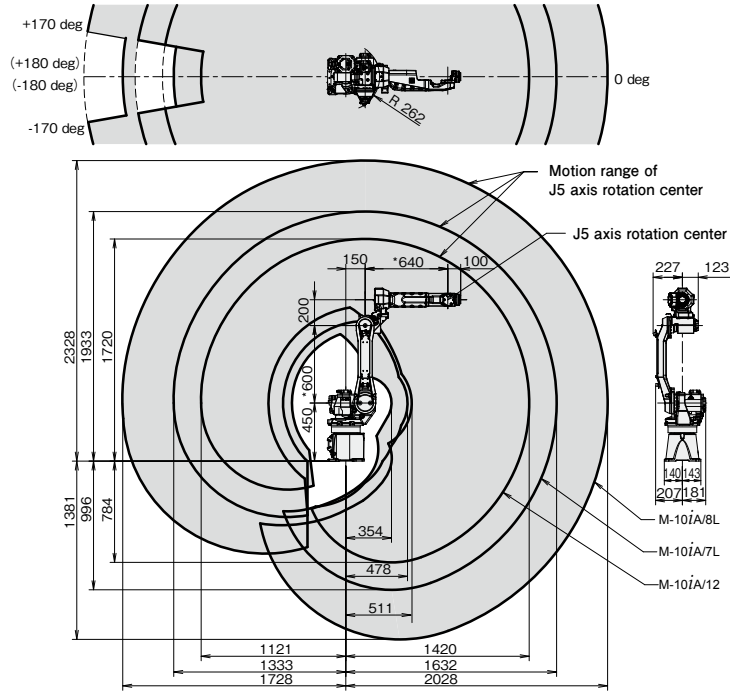

*J2 arm length
 M-10iA/12 : 600mm
 M-10iA/7L : 600mm
 M-10iA/8L : 780mm

*J3 arm length
 M-10iA/12 : 640mm
 M-10iA/7L : 860mm
 M-10iA/8L : 1080mm

Specifications

Model		M-10iA/12	M-10iA/7L	M-10iA/8L
Controlled axes		6 axes (J1, J2, J3, J4, J5, J6)		
Reach		1420mm	1632mm	2028mm
Installation		Floor, Upside-down, Angle mount		
Motion range (Maximum speed) (Note 1, 2)	J1 axis rotation	340°/360° (Option) (230°/s) 5.93 rad/6.28 rad (Option) (4.01 rad/s)		340°/370°(Option) (200°/s) 5.93 rad / 6.45 rad°(Option) (3.49 rad/s)
	J2 axis rotation	250° (225°/s) 4.36 rad (3.93 rad/s)		255° (200°/s) 4.45 rad (3.49 rad/s)
	J3 axis rotation	445° (230°/s) 7.76 rad (4.01 rad/s)	447°(230°/s) 7.80 rad(4.01 rad/s)	462° (210°/s) 8.06 rad (3.67 rad/s)
	J4 axis wrist rotation	380° (430°/s) 6.63 rad (7.50 rad/s)		400° (430°/s) 6.98 rad (7.50 rad/s)
	J5 axis wrist swing	380° (430°/s) 6.63 rad (7.50 rad/s)		360° (430°/s) 6.28 rad (7.50 rad/s)
	J6 axis wrist rotation	720° (630°/s) 12.57 rad (11.0 rad/s)		900° (630°/s) 15.71 rad (11.00 rad/s)
Maximum load capacity at wrist		12 kg	7 kg	8 kg
Allowable load moment at wrist	J4 axis	22.0 N·m	15.7 N·m	16.1 N·m
	J5 axis	22.0 N·m	10.1 N·m	16.1 N·m
	J6 axis	9.8 N·m	5.9 N·m	5.9 N·m
Allowable load inertia at wrist	J4 axis	0.65 kg·m ²	0.63 kg·m ²	0.63 kg·m ²
	J5 axis	0.65 kg·m ²	0.38 kg·m ²	0.63 kg·m ²
	J6 axis	0.17 kg·m ²	0.061 kg·m ²	0.061 kg·m ²
Repeatability		± 0.08 mm		
Mass (Note 3)		130 kg	135 kg	150 kg
Installation environment		Ambient temperature : 0 to 45°C Ambient humidity : Normal 75 %RH or less (No dew not frost allowed), Short term 95 %RH or less (within one month) Vibration acceleration : 4.9 m/s ² (0.5G) or less		

Note 1) In case of angle mounting, J1 and J2 axis motion range are restricted.

Note 2) In case of short distance motion, the axis speed may not reach the maximum value stated.

Note 3) Without controller

FANUC CORPORATION

Headquarters Oshino-mura, Yamanashi 401-0597, Japan
 Phone: 81-555-84-5555 Fax: 81-555-84-5512 <http://www.fanuc.co.jp>

- Overseas Affiliated Companies
- FANUC America Corporation
- FANUC Europe Corporation, S.A.
- SHANGHAI-FANUC Robotics CO., LTD.
- KOREA FANUC CORPORATION
- TAIWAN FANUC CORPORATION
- FANUC INDIA PRIVATE LIMITED
- FANUC SINGAPORE PTE. LTD.
- FANUC THAI LIMITED
- FANUC MECHATRONICS (MALAYSIA) SDN. BHD.
- PT. FANUC INDONESIA
- FANUC OCEANIA PTY. LIMITED
- FANUC SOUTH AFRICA (PROPRIETARY) LIMITED

- 3900 West Hamlin Road, Rochester Hills, MI 48309-3253, U.S.A.
- Zone Industrielle, L-6468 Echternach, Grand-Duché de Luxembourg
- No. 1500 Fulian Road, Baoshan Area, Shanghai, China
- 101, Wanam-ro(st), Seongsan-gu, Changwon-si, Gyeongsangnam-do, 642-290 Republic of Korea
- No.10, 16th Road, Taichung Industrial Park, Taichung, Taiwan
- 41-A, Electronics City, Bangalore, 560 100, India
- No.1 Teban Gardens Crescent, Singapore 608919, Singapore
- 1301 Pattanakarn Road, Kwaeng Suanluang, Khet Suanluang, Bangkok 10250 Thailand
- No.32, Jalan Pengacara U1/48, Temasya Industrial Park, Section U1, Glenmarie, 40150 Shah Alam, Selangor Darul Ehsan, Malaysia
- JL. Boulevard Bukit Gading Raya Blok R, Jakarta 14240 Indonesia
- 10 Healey Circuit, Huntingwood, NSW 2148, Australia
- 17 Loper Ave, Aeroport Industrial Ests. Spartan Ext.2 P.O.Box 219, Isando 1600, Republic of South Africa

- Phone: 1-248-377-7000 Fax: 1-855-774-7051
- Phone: 352-727777-1 Fax: 352-727777-403
- Phone: 86-21-5032-7700 Fax: 86-21-5032-7711
- Phone: 82-55-278-1200 Fax: 82-55-284-9826
- Phone: 886-4-2359-0522 Fax: 886-4-2359-0771
- Phone: 91-80-2852-0057 Fax: 91-80-2852-0051
- Phone: 65-6567-8566 Fax: 65-6566-5937
- Phone: 66-2-714-6111 Fax: 66-2-714-6120
- Phone: 60-3-7628-0110 Fax: 60-3-7628-0220
- Phone: 62-21-4584-7285 Fax: 62-21-4584-7288
- Phone: 61-2-8822-4600 Fax: 61-2-8822-4666
- Phone: 27-11-392-3610 Fax: 27-11-392-3615

- All specifications are subject to change without notice.
- No part of this catalog may be reproduced in any form.
- The products in this catalog are controlled based on Japan's "Foreign Exchange and Foreign Trade Law". The export from Japan may be subject to an export license by the government of Japan. Further, re-export to another country may be subject to the license of the government of the country from where the product is re-exported. Furthermore, the product may also be controlled by re-export regulations of the United States government. Should you wish to export or re-export these products, please contact FANUC for advice.